

60033[12V100Ah]

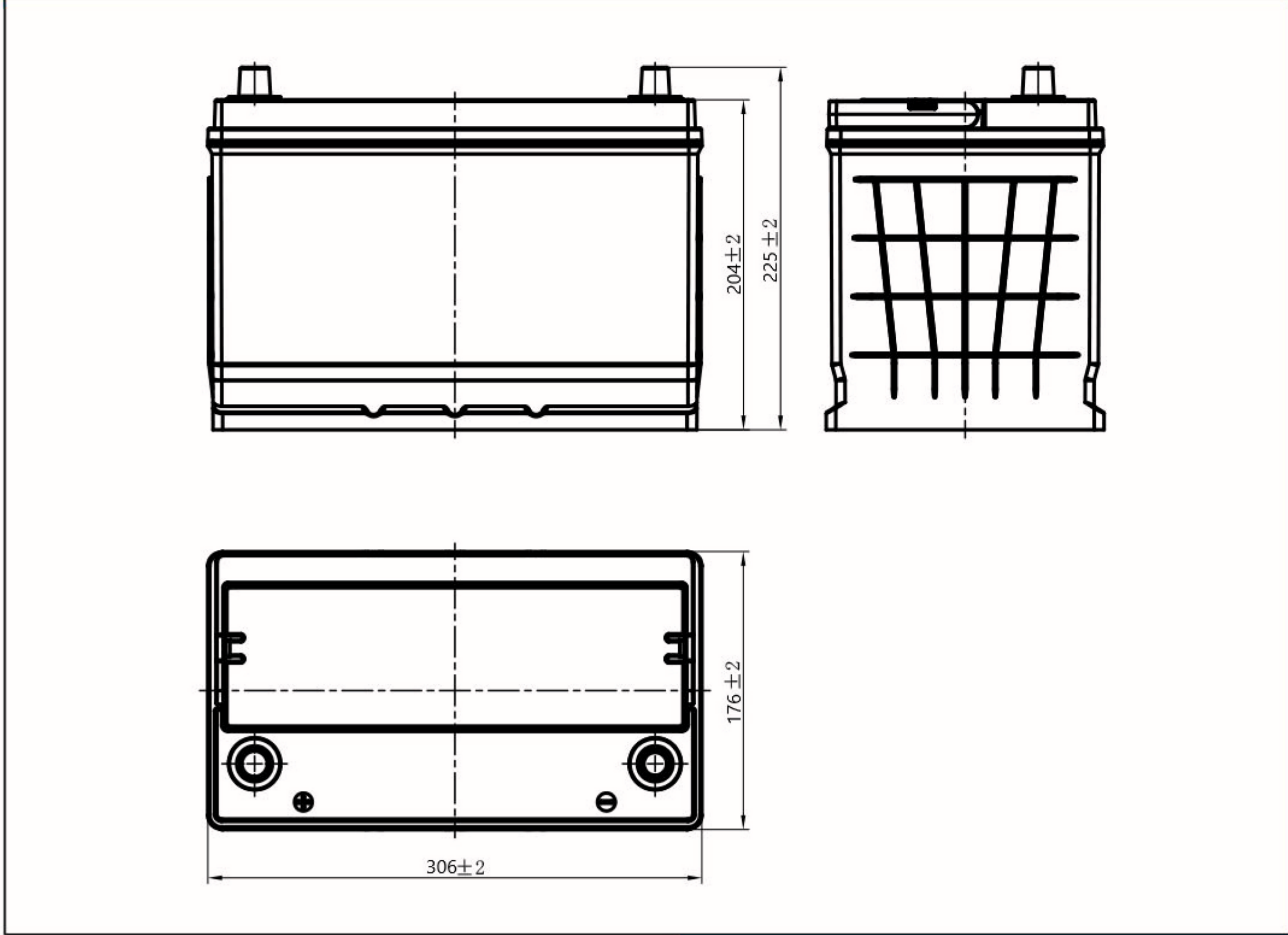

Dimensions (mm)



Physical Specification (mm)

Nominal Voltage		12V
Nominal Capacity(20HR)		100Ah
Dimension	Length	306±3mm(12.0inches)
	Width	176±2mm(6.73inches)
	Container Height	204±2mm(7.99inches)
	Total Height(with Terminal)	225±2mm(8.82inches)
Weight		Approx22.6Kg(49.82lbs)
Acid		1.280±0.015g/cm ³ (25°C)
Standard Terminal		1
Cell layout		1
Hold-Down		B1
Cell plate qty		/
Case		Gray-PP Material
Cover		Gray-PP Material
Handle		Gray-PP Material
QTY/PLT/layer		/

Electrical Specification

Rated Capacity	20 hour rate(4.50A)	100Ah
Reserve Capacity		158min
Cold Cranking Performance Amps@0°F(-18°C)		750A

Discharge Characteristics(25°C,77°F)

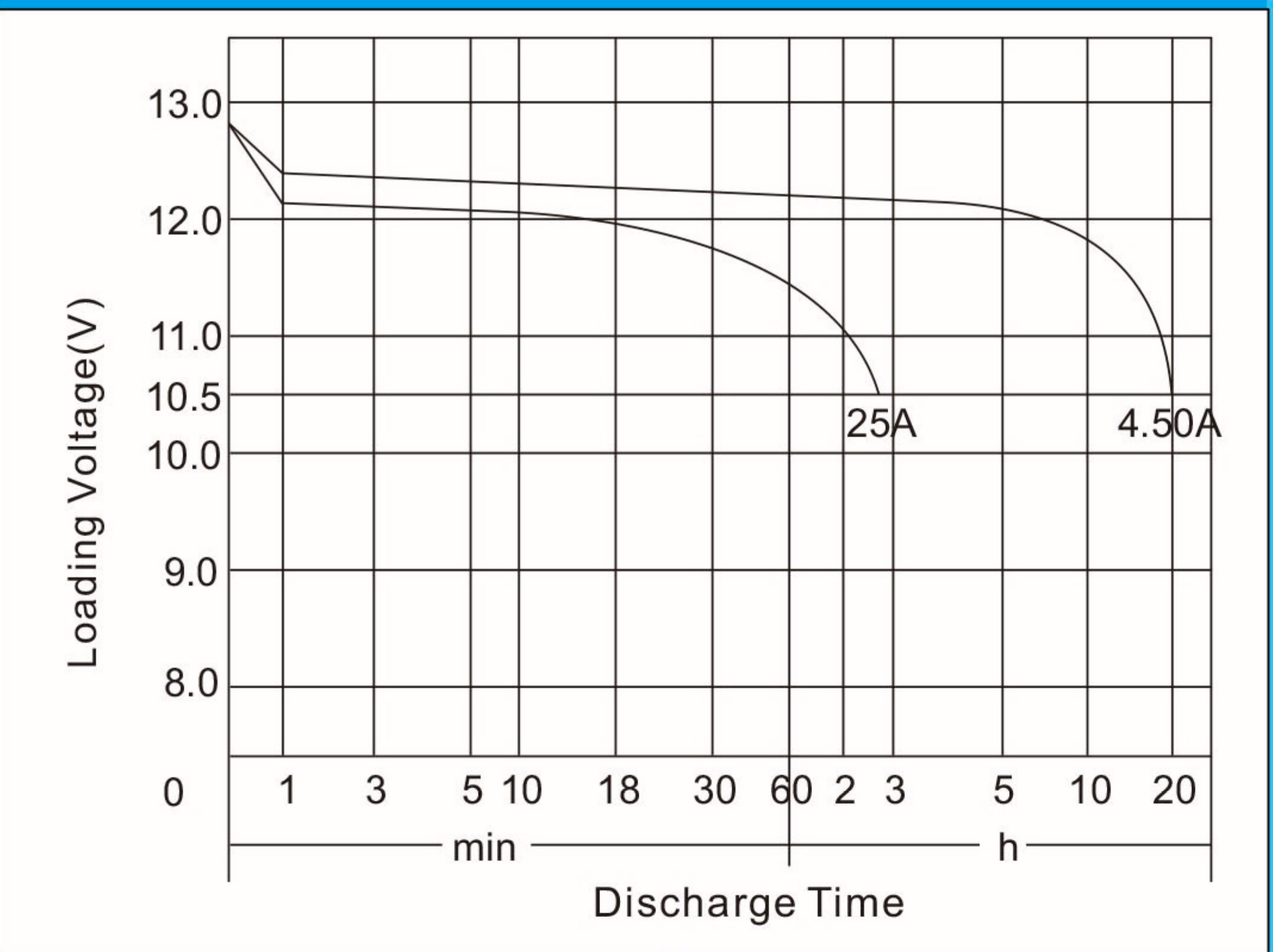

Standard Terminal (mm)

Terminal Type	D	
	Positive	Negative
1	19.5 ⁰ _{-0.3}	17.9 ⁰ _{-0.3}

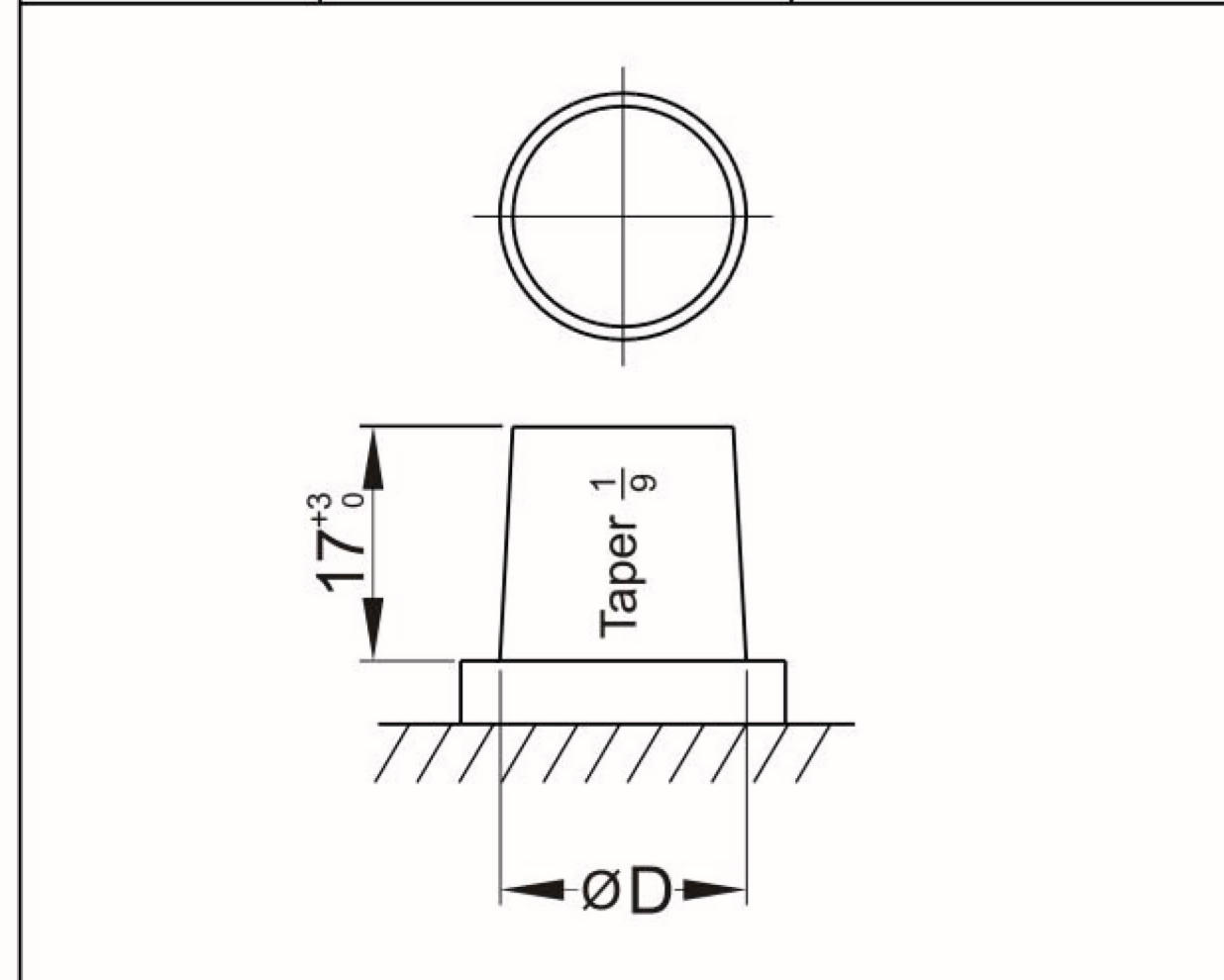

Cell Layout

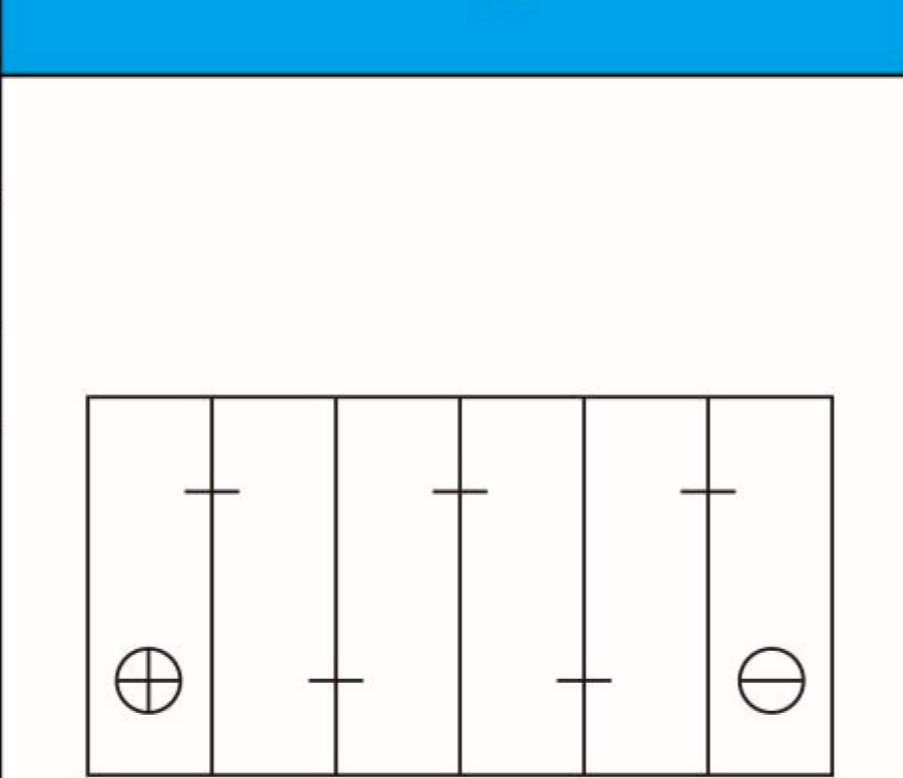

Figure(1)

Discharge Characteristics(-18°C,0°F)

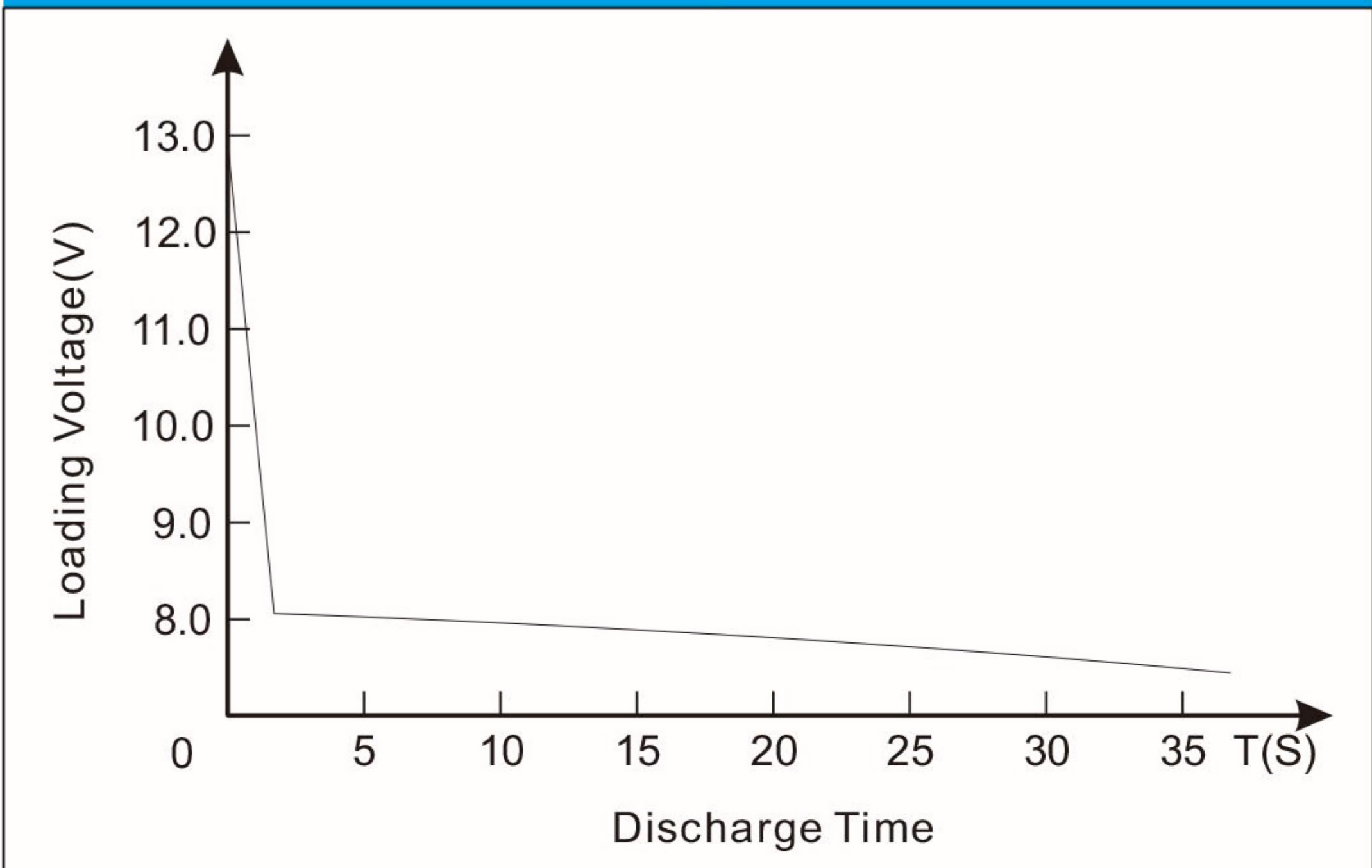

*Values are subject to variation of +/- 5% in normal manufacturing processes.
*Technical specifications and the product line above could be changed without prior notice.